

## DFD6361 Half-cut Specification Machine Directive (CE Marking) Specification Instruction Manual Request to Correct Errors Regarding Cover Configuration and Safety Switch Position

### Request for verification and correction

There were errors in the explanation of the cover configuration and safety switch position included in the Machine Directive (CE Marking) Specification Instruction Manual for the DFD6361 Half-cut Specification. Please correct them after verifying the details.

### Error detail 1: error relating to cover configuration

For the CE marking-adapted machine, the manual indicated that there was a single-cover configuration (cover N) combining cover B and cover C, but this is an error. The covers are the same as the standard machine.

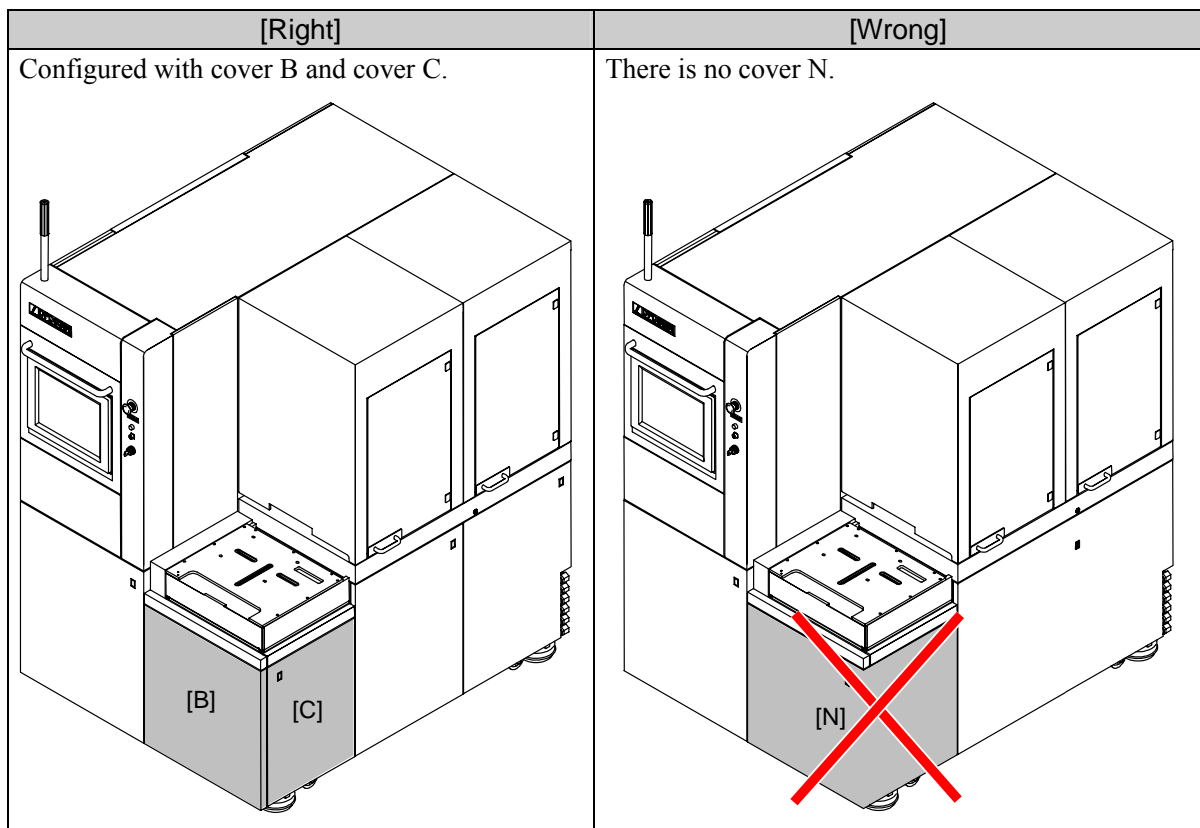

## Error detail 2: error relating to safety switch position

The manual indicates that the safety switch is mounted on the right side of cover N, but this is an error. The safety switch is mounted on cover B (front of machine). There is no safety switch mounted on cover C (right side of machine).

The interlock will not activate even if cover C is opened.

It is not possible to operate the machine while cover B is not attached.

When cover B is opened, the interlock will activate.

### [Machine status after interlock is activated]

- X-, Y1-, Y2-,  $\theta$ -axes, (Full-cut: Frame centering axis), elevator-axis, upper arm, lower arm, Robot pick (Full-cut: push-pull arm), spinner rotation-axis and nozzle-axis will all be stopped immediately.
- Z1-, Z2-axes will move to the up-end position and stop there.
- Stop of supply of wheel coolant water
- Stop of rotation of spindle
- In case a hazard is detected while the spinner cleaning is under way, the cleaning operation will stop.

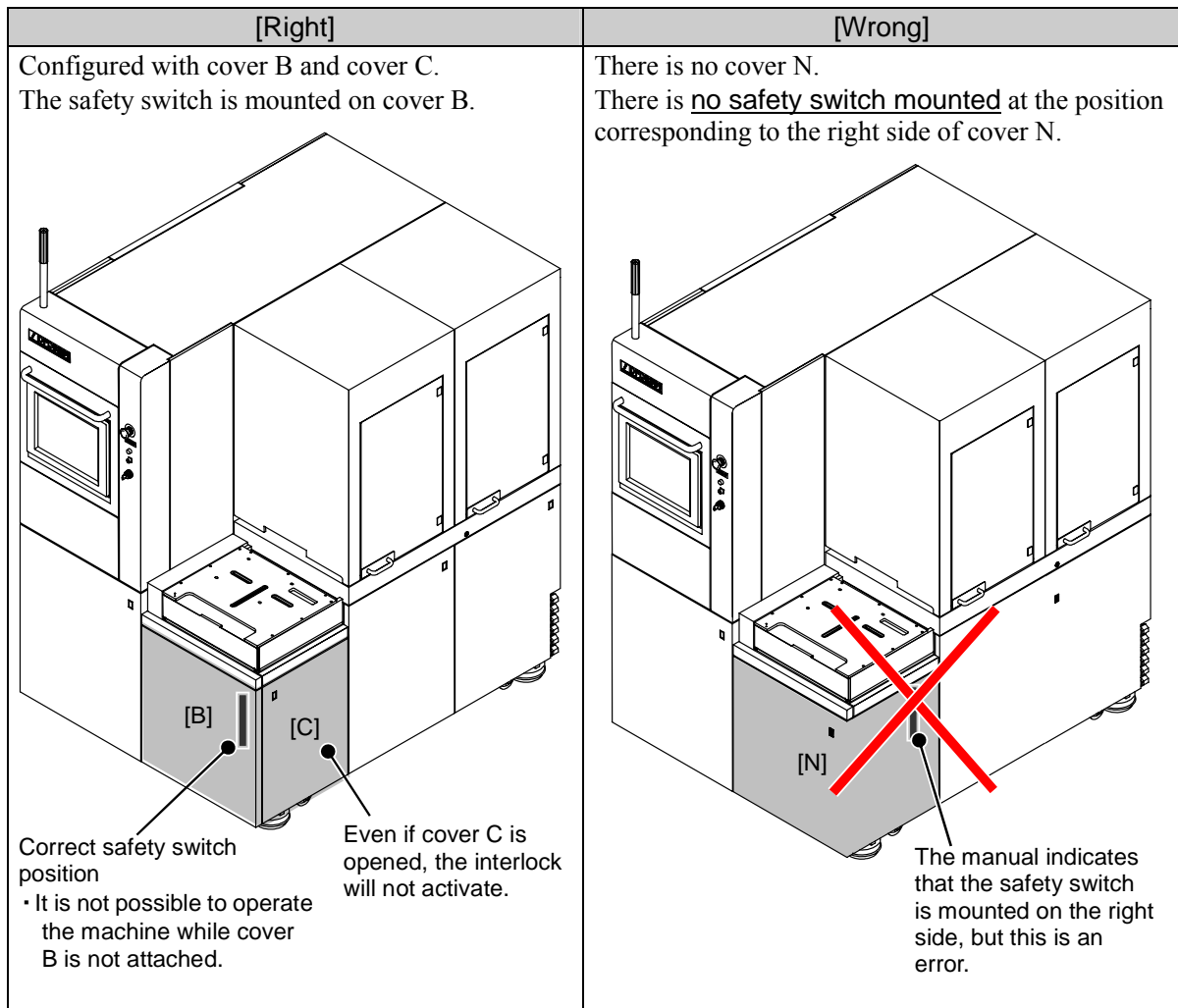

# Technical Newsletter

#tnl2016-0015e

# 3 / 3



---

## Relevant instruction manuals and pages including error details

---

The relevant pages with the errors corrected are included with this document. Please insert them instead of the pages with errors in the manual and use them.

Language	Part No.	Page including error detail 1	Page including error detail 2
Japanese	UKFWVJH8C0A	A-9	A-12
	UKFWVJH8C0B		
English	UKFWVEH8C0A	A-8	A-11
	UKFWVEH8C0B		

---

## Feature 7: Change in the Configuration of the Outer Cover

### Feature 7: Change in the Configuration of the Outer Cover

The configuration of the outer covers has been changed as shown below for CE marking specification.

- Covers [D] and [E] have been integrated together and changed in order to comprise 1 cover (cover [M]).

For CE marking specification, please understand the following for the covers indicated in the manuals included as standard accessories.

- Covers [D] and [E] should be understood as meaning cover [M].

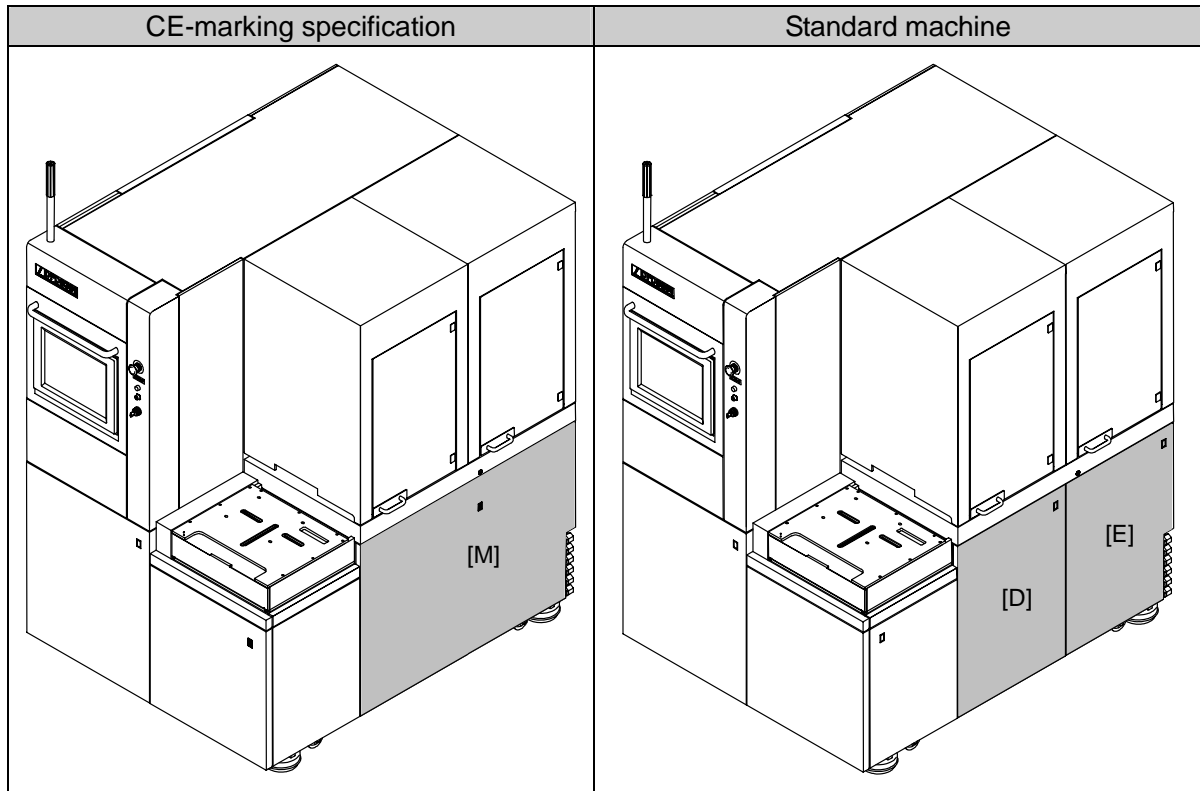

Interlock devices of the machine outer cover (The machine outer cover (partition (left), [P], [B], [M] and [R] cover) labeled with **COVER INTERLOCK** is equipped with interlock devices.)

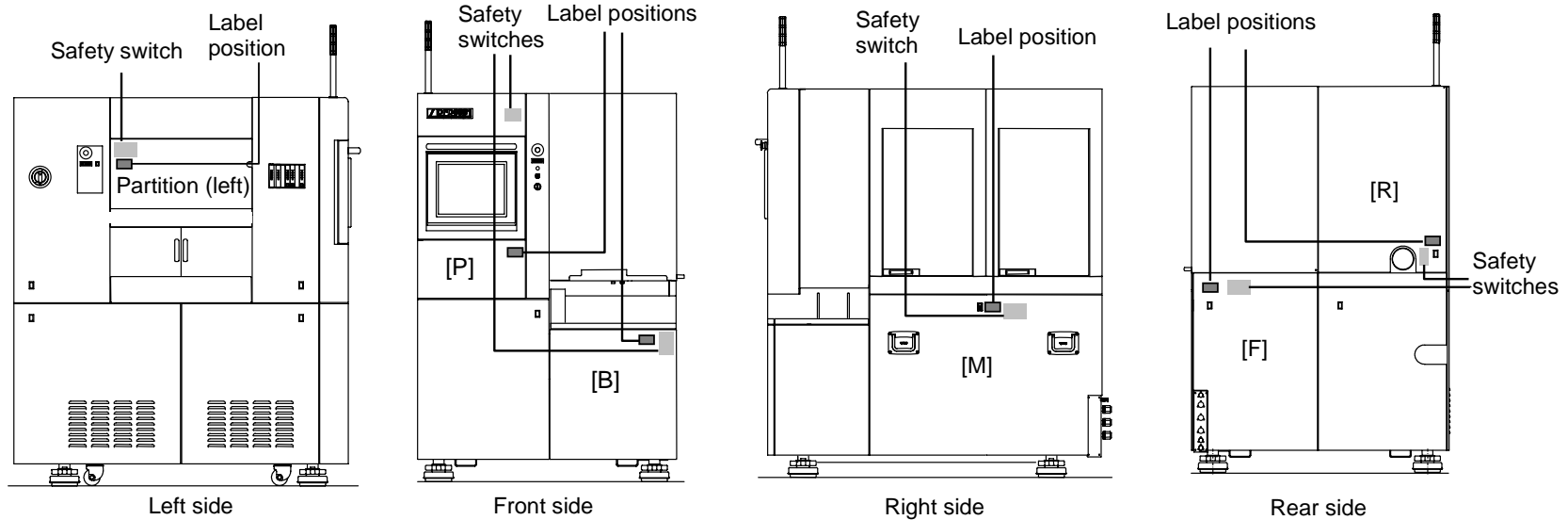

Interlock device		Hazards	Hazardous area	What will happen after the interlock device is actuated
Item	DISCO Part ID.			
Safety switch	SWITCH (SAFETY DOOR) EKKM-010006-0	<ul style="list-style-type: none"> <li>• Amputation</li> <li>• Pinch</li> </ul>	<ul style="list-style-type: none"> <li>• Spindle rotation</li> <li>• X-axis movement</li> <li>• <math>\theta</math>-axis rotation</li> <li>• Y1-axis movement</li> <li>• Y2-axis movement</li> <li>• Z1-axis movement</li> <li>• Z2-axis movement</li> </ul>	<ul style="list-style-type: none"> <li>• X-, Y1-, Y2-, <math>\theta</math>-axes, (Full-cut: Frame centering axis), elevator-axis, upper arm, lower arm, Robot pick (Full-cut: push-pull arm), spinner rotation-axis and nozzle-axis will all be stopped immediately.</li> <li>• Z1-, Z2-axes will move to the up-end position and stop there.</li> <li>• Stop of supply of wheel coolant water</li> <li>• Stop of rotation of spindle</li> <li>• In case a hazard is detected while the spinner cleaning is under way, the cleaning operation will stop.</li> </ul> <p><u>If the cover is disengaged, the machine cannot be operated.</u></p>